

YONGMA ENGINEERING

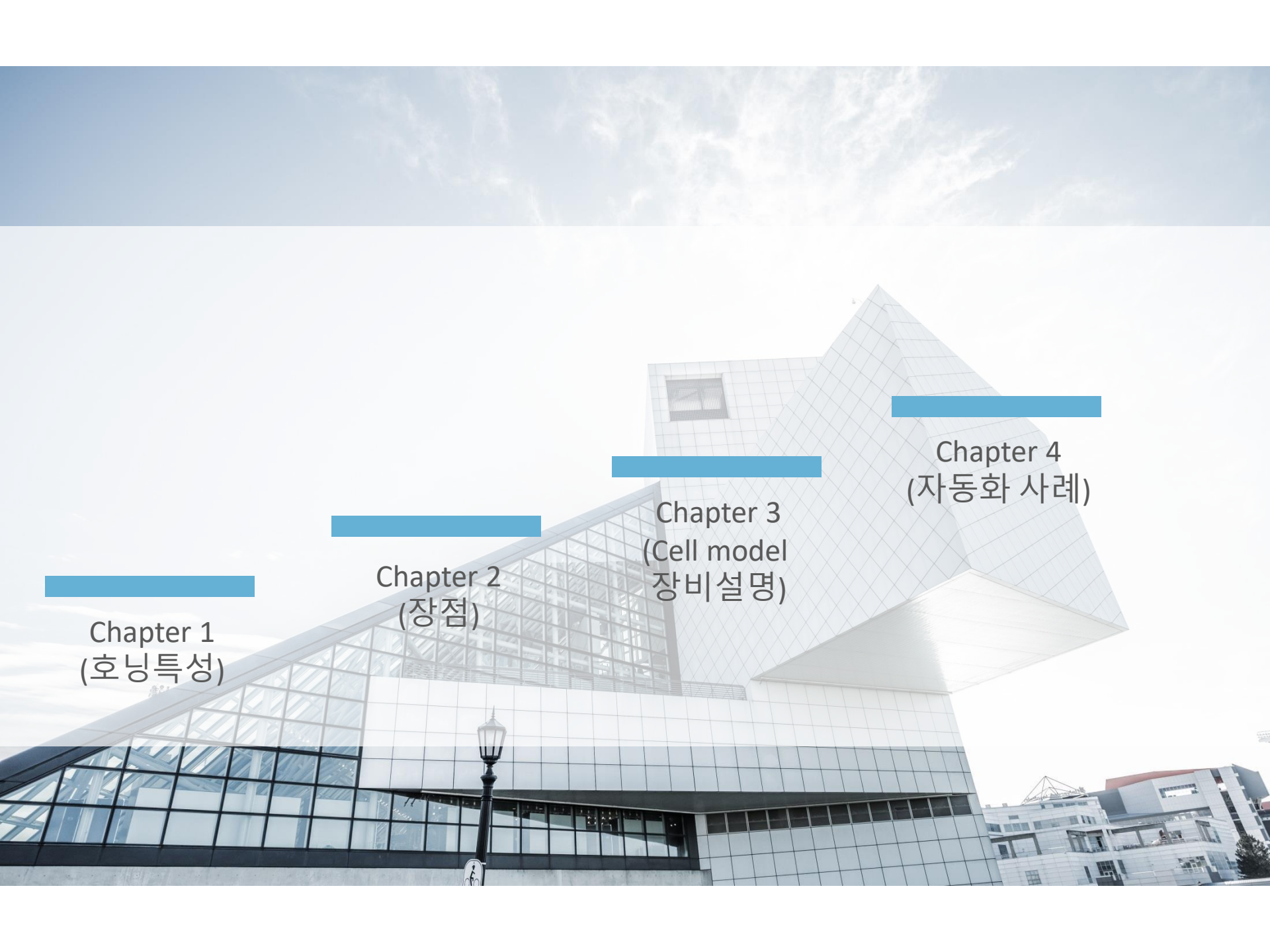



Chapter 1
(호닝특성)

Chapter 2
(장점)

Chapter 3
(Cell model
장비설명)

Chapter 4
(자동화 사례)

Chapter 01

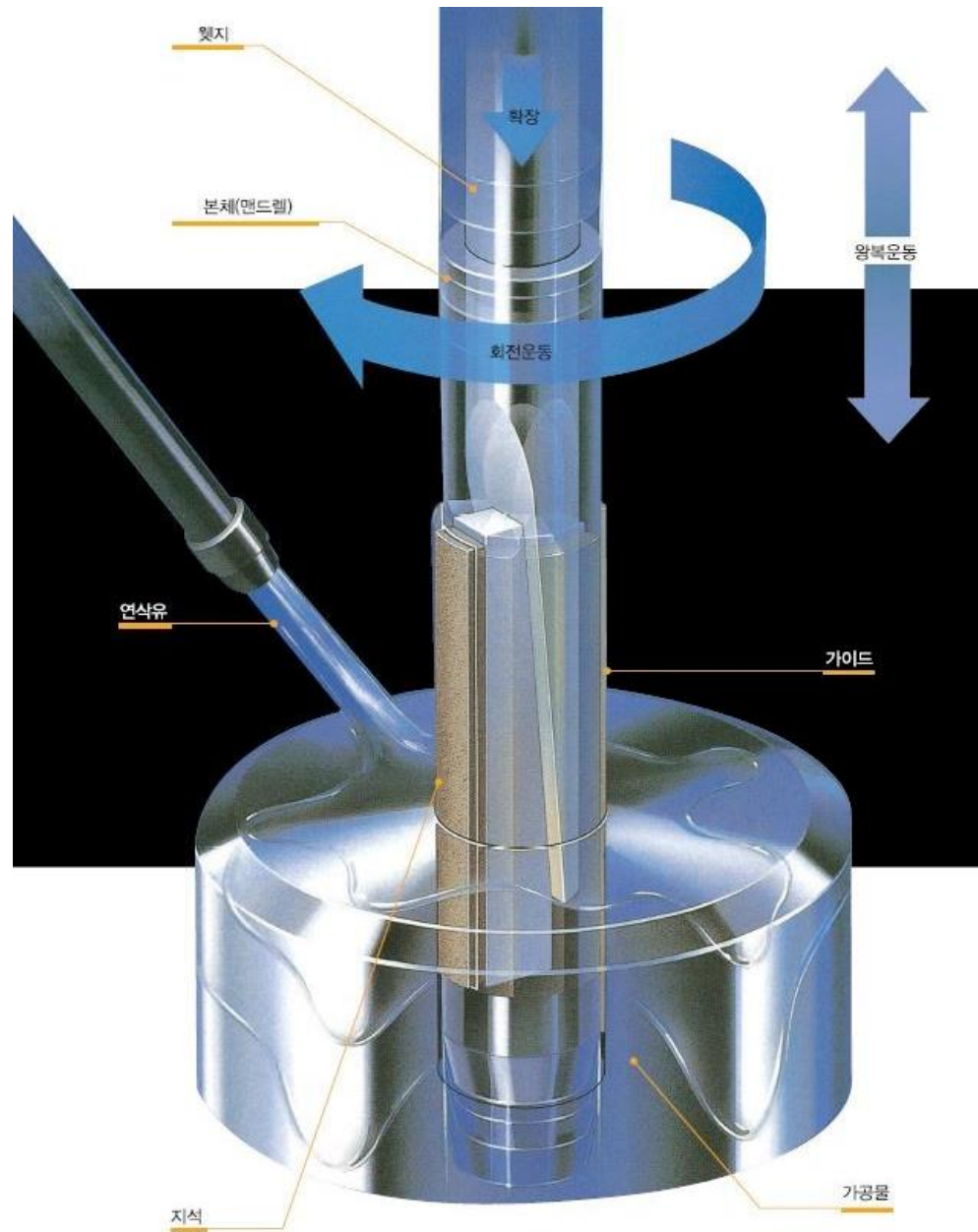

장점

- 안정된 절삭성 : 절삭 시 토크를 모니터링
- 고 정밀도 : 원통도 최대 0.7um 달성 가능
- 슬라이드 면의 확보
: 가공면이 해치면이 되어 기름띠의 형성 유지
- 호닝 가공 후 계측하여, 자동 톨 보정가능
- 공간 15~30%절약 (당사 대비)

Chapter 03

2축 가공 셀

투입 셀

리턴 셀



Chapter 03

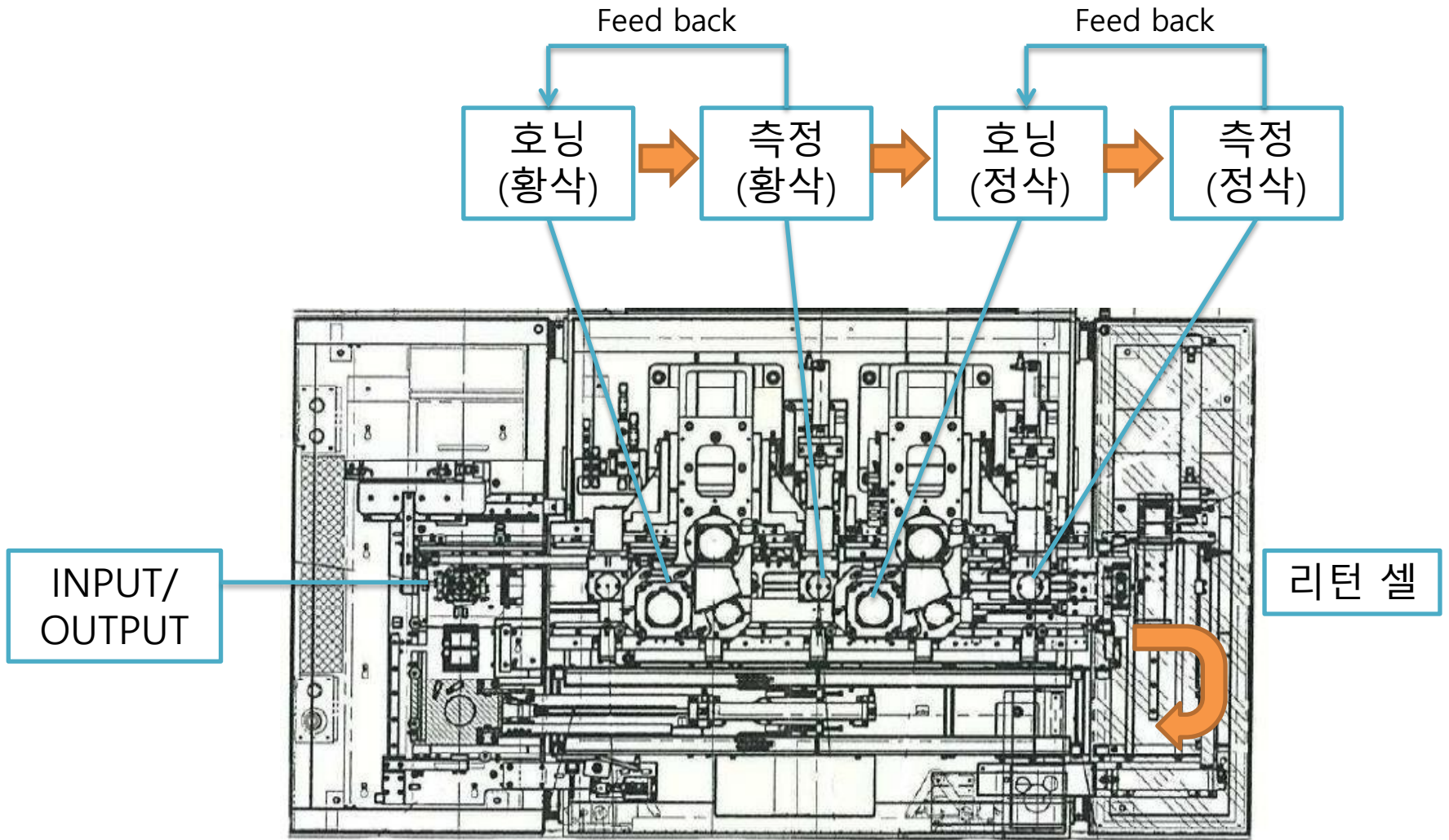

Chapter 03

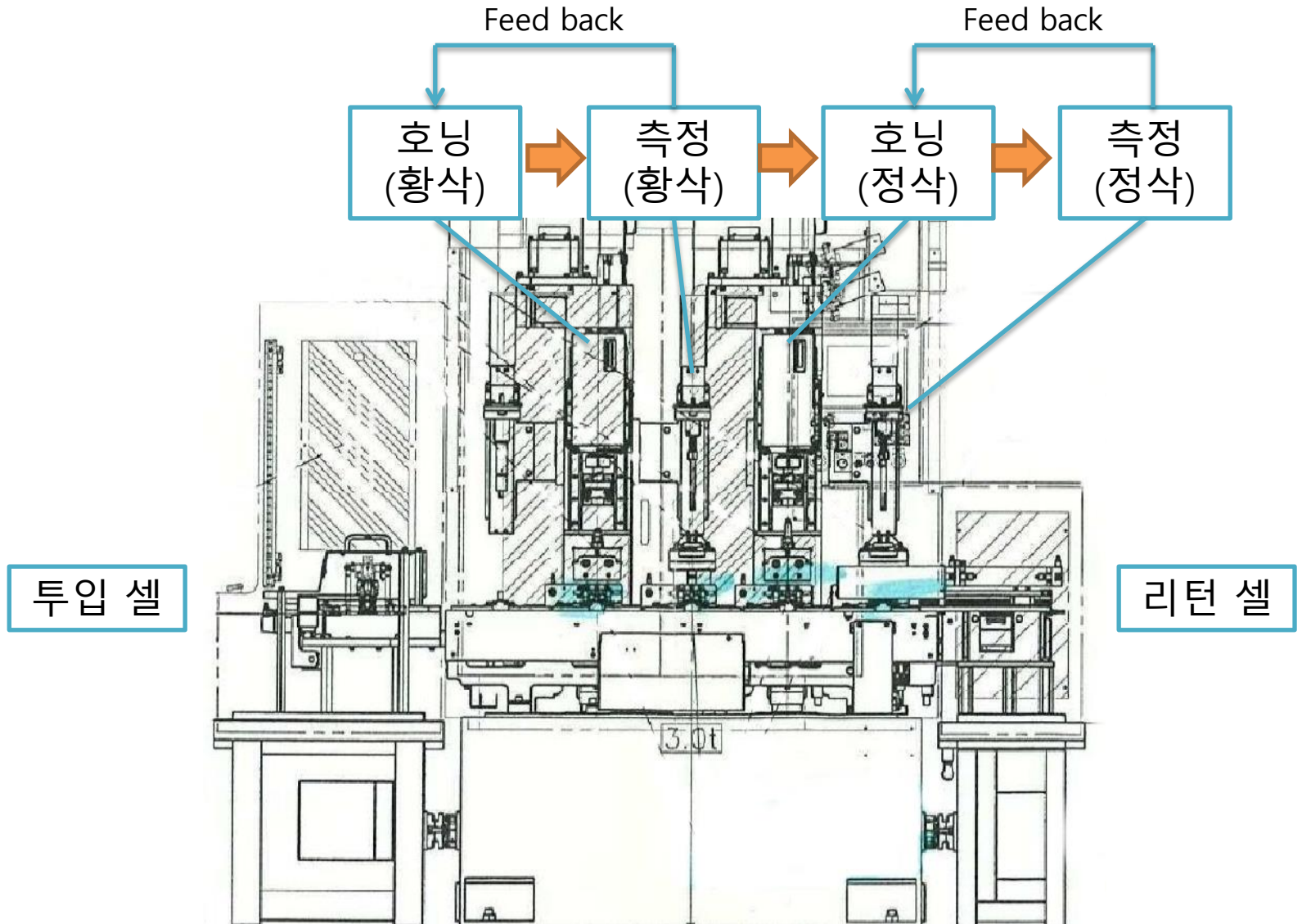

Chapter 04



THANK YOU

:)

